

DPC-320 FUME HOOD CONTROL SYSTEM

- Ultra low actual face velocity measurement
- Millisecond response time of the control
- Excellent measurement sensor repeatability
- Total air tight shut off capability
- Pressure independent damper control
- Long term velocity measurement stability
- Ultra low hysteresis of the control action
- Extract Volume limiting and supply tracking
- Operator Panel with alarms and exhaust
- Modbus rtu Communication to BMS and PLC's
- After Sales Service is provided by CMR
- 24 month warranty
- 30 Years field application experience

The DPC-320 has been especially designed for Fume Hood control operation to fit any fume cupboard manufacturers equipment and is ready for installation as a complete factory commissioned system. The most important advantage is that it can control any type of fume hood without the need to connect to moving sash parts such as drive mechanisms, sash position sensors or the fitting of sash height measurement potentiometers.

The DPC-320 FC-Controller measures the differential pressure between the fume hood inner body and the Laboratory which is a very low pressure of 0.15 Pa. This measurement is converted into a velocity, which represents 0.50 m/s face velocity. The measurement tubes are connected to the DPC without any wiring of an independent sensor. The DPC-320 maintains 0.50 m/s linear face velocity at all times regardless of the sash type, vertical or horizontal, with or without sliding windows. This means the sash can be closed down to 10mm or opened to 500mm or higher and the face velocity will remain at 0.50 m/s. The set point is user adjustable from 0.30 to 1.00 m/s.

The velocity measurement is factory calibrated and only a check has to be carried out to issue a site certificate. All the face velocity calibration can be done via the operator keyboard panel without a lap top or climbing to the top section where the controller is located.

The DPC-320 is mounted on a PPs Valve which has also a fast acting actuator. The unit is normally powered by 230Vac and pre-wired. 24Vac and 110Vac is also available. A modbus rtu communication is standard, so that the complete system can be monitored and commanded via the local BMS or PLC control system. The PPs Valve has a built in Venturi total air volume measurement device. The valves are supplied in sizes of 160, 200,250,315, 400, 450 and 500 mm Ø with flanges.

The DPC-320 has an additional sensor which measures the volume on the venturi and limits the extract volume so that the design of the laboratory is respected at all times and the central extract fan cannot run out of its design capacity. If there are 100 Fume Hoods and each is designed to extract 0.3m³/s then this is the limit and sufficient extract air will be available to all other fume hoods throughout the building.

Night set back set points are programmable i.e. 0.30m/s and normally set points can be adjusted up to 1m/s and emergency exhaust functions can go up to 2m/s.

The operators control panel is fitted to the front on the side or below the tray of fume hood and the actual face velocity and alarms, actual extract volume, position of damper, and face velocity is displayed. An emergency exhaust button is there to exhaust quickly in case of spillage. Custom panels are CMR's speciality.



DPC-320 Fume Hood Controller

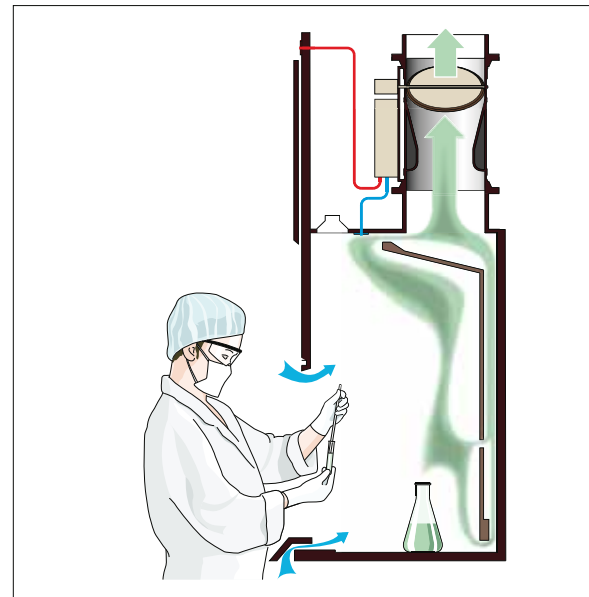

DPC-320 Fume Hood Air Pattern Control



CMR Fume Hood Controllers in operation

CMR CONTROLS Ltd
Precision Air Pressure and Volume Sensors

22 Repton Court Repton Close
Basildon Essex SS13 1LN GB
web www.cmr-controls.com

Phone +44 (0) 1268 287222
Fax +44 (0) 1268 287099
mail sales@cmr-controls.com



VAK FUME VENTURI AIR CONTROL VALVE

PPs PLASTIC, GALVANIZED OR STAINLESS STEEL VALVES

The CMR VAK Fume Extract Valve is made of PPs and is circular. It has a Venturi Flow Measurement device built in. Alternatively the VVR range of valves can be manufactured in galvanised steel with PUR and epoxy coated or stainless steel to suit many applications. The actuator and DPC-320 controller is factory fitted to the valve and fully tested and ready for installation. The sizes available are 160, 200, 250, 315, 400, 450 and 500 in all materials and in metal coated thereafter in 560 and 630mmØ.

VENTURI VOLUME MEASUREMENT

The valves have a venturi extract volume measurement which is used to control the make up supply air. The extract volume is measured and volume limiting is achieved. Regardless how high the sash is lifted, the volume shall be controlled to the max design volume. In addition, the total volume shall be added of all fume hoods in a laboratory in order to match the supply air volume.

All CMR valves are airtight to DIN 1946 T4. The CMR range of actuators are able to drive the valve to a total shut off position, which is of great advantage in case of maintenance or isolation work to be carried out. All CMR Valves work up to 1000 Pa duct pressure. The Valve is totally pressure independent and shall adjust to provide a constant face velocity at fluctuating extract pressure. The Valve sizes should be selected to provide a minimum velocity preferably above 2 m/s in the extract duct at minimum sash height to be able to read the extract volume **accurately if this volume is to be used to control the make up air.**

Valve Body Construction

The FCR Venturi Valve is manufactured to the highest engineering precision with CNC machines. The valve is manufactured from a pipe extrusion with all cut outs for the damper blade axle and the tube fittings. The Venturi is formed and welded into the body. All tube connections are welded. The damper blade consists of discs with a seal. A heavy duty drive shaft is fitted onto the valve blade and is then embedded into air tight bearings on both sides of the valve to provide smooth action with very low torque. All components which are in the air stream are either PPs or PPs coated. The blade and drive shaft are designed for very fast motor rotation i.e. 1 second from open to closed position.



VAK Venturi Valve with fast Actuator on mounting bracket

Venturi Construction

The Venturi is designed for each Size and formed to the same precision with CNC machines. It consists of total averaging pressure measurement holes on the inlet of the venturi. The venturi is welded into the inside of the valve which has a reduced open area. The air is forced through the nozzle at higher speed and static averaging pressure holes pick up the increased static pressure.

Venturi Measurement

The total and the static pressure is then converted by the CMR Volume Sensor into a scaled and linear air volume providing either l/s, m3/s or m3/h. The venturi in combination with the CMR Sensors and DPCs are factory calibrated and provide an accurate and repeatable measurement.

Due to the very unique shape of the venturi, the pressure is regained and a low total overall pressure drop is achieved.

VAK Venturi PPs Valve with DPC Controller and fast Actuator 0-90° and Modbus rtu communication

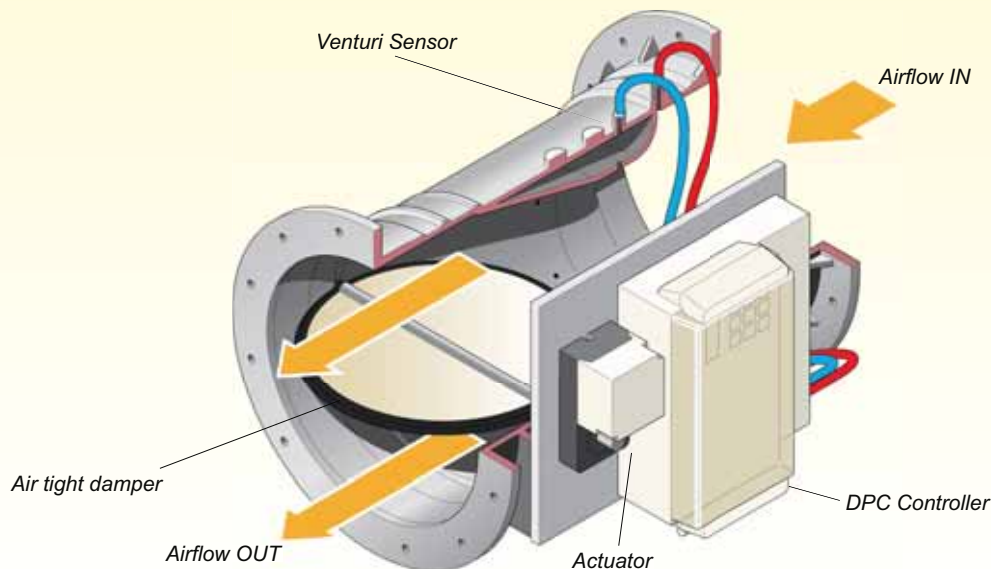

DPC-320 FUME HOOD VAV CONTROL

CMR FACE VELOCITY SENSOR

The CMR Sash face velocity sensor is a unique electronic velocity measuring device which works on the principle of differential pressure measurement between inside the Fume Cupboard and the laboratory. It is built into the DPC-320 Controller. The sampling points shall be installed by drilling and fitting a CMR Bulkhead into the top inside ceiling of the Fume Hood. An equal length of blue PVC tubing is connected to either Bulkhead and a T-Piece and is then connected to the negative port of the DPC-320. The bulkheads and tubing for the face velocity sensing can either be installed by the Fume Hood manufacturer or it can be installed easily on site. The negative suction within the Fume Cupboard pulls a sample of the air through the CMR Precision Sensor via two sampling point on the top front face of the Fume Hood which is connected via a red PVC tube to a Bulkhead and the DPC-320.

The air, which is drawn from the clean Laboratory air is filtered by a CMR particle filter which is totally maintenance free. The sensing element heats the sampled air to 160°C on a ceramic base and by means of differential temperature measurement the face velocity is determined and scaled. Micron dust particles will be burnt off and therefore the sensor shall never contaminate.

The CMR face velocity sensor provides an output signal which represents the front face velocity of the sash. The CMR sensor is linear over a range of 0.30 to 1.00 m/s over any sash height between 10mm and 500mm or higher. The installation is extremely easy and can be done on site on any Fume Hood Make. For maximum energy saving it is essential that the Fume Cupboard is well sealed between the Glass front and the top compartment of the Fume Cupboard.

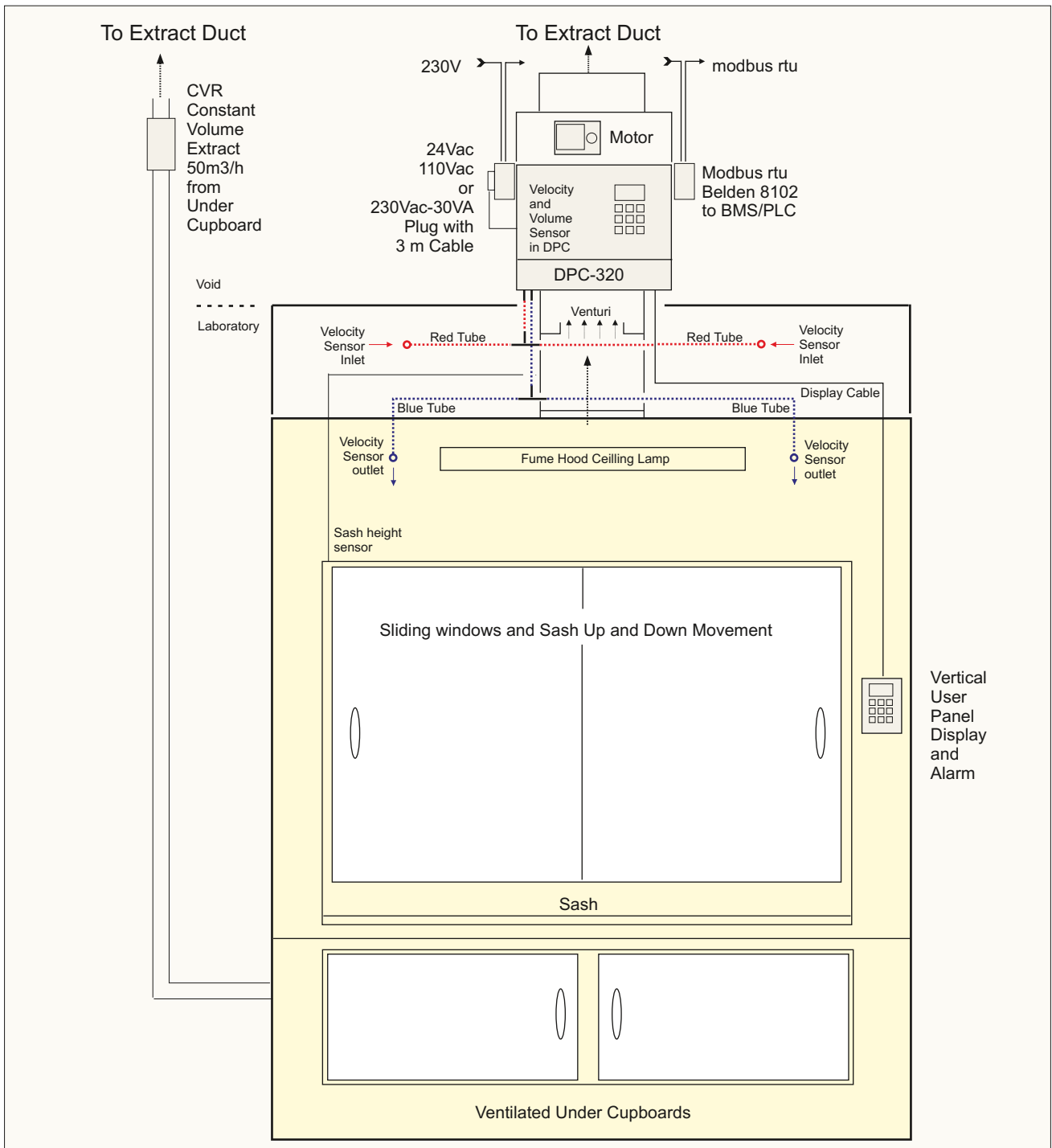

DPC-320 FUME HOOD

DESCRIPTIONS

CMR Series Actuators

The CMR fast running actuators are 3s for 0-90° with 8Nm and are supplied for valves up to 400mm Ø. Larger Valves are fitted with an actuator having 16Nm going from 450mmØ. up to 630mmØ. They are the most popular actuators to work in conjunction with the DPC-320 Controllers. The actuators are 24Vac with an input signal of 2..10V and a position feed back of 2..10V. The angle of rotation can be mechanically as well as electrically limited on either side. The actuator drive has the latest technology and is equipped with a hi-tech electric motor which can withstand the extreme movements of opening and closing the damper.

DPC-320 CONTROLLER

The Power Supply can be 24, 110 or 230Vac 50/60Hz and shall be fitted with a plug and cable to suit any Country. The power can also be connected to terminals inside the controller. All fuses and power supplies to operate the controller, motor and display plate are incorporated within the controller. The controllers front control panel is protected by a clear IP 65 window lid. The LCD display indicates the actual face velocity in m/s, position of damper, extract volume and the control set point.

A keyboard is on the front plate with HAND/AUTO and when selecting the Hand position the valve can be opened or closed via the up and down keys. This is ideal for maintenance or other shut down purposes. A low and high alarm threshold set point can be adjusted. A built in timer times out the low or high alarm and switches on a red LED on the keyboard. A mute key is fitted to mute the alarm either momentary or permanently. All parameters can be adjusted via the keyboard, which is operator password protected.

REMOTE DISPLAY OPERATOR PANEL

The buzzer and all functions are built into the remote alarm display plate and can be fitted on the fume cupboard front. Custom made designs to suit the clients fume cupboards are available from CMR. The remote keyboard is connected via a single multi core cable from the DPC-320 and is easily fitted on site. The Operator Display panel has an emergency exhaust key and a mute alarm key. All measurements are indicated on the LCD display such as actual face velocity i.e. 0.50 m/s, set point, position of damper, software version and node address. All other parameters can be displayed and adjusted via password access.

SASH HIGH SENSOR

The sash high sensor is easily connected and the Fume Hood manufacturer normally has sash high built in digital switch which can be connected into the DPC-320

AUTOMATIC SASH OPENING - CLOSING

If the Fume hood is equipped with an automatic sash drive open or close system via a proximity sensor then the DPC-320 has a digital input in order to re-set the face velocity set point from 0.50m/s to 0.30m/s to reduce the air extract volume for energy saving.

MODBUS COMMUNICATION

The DPC-320 is equipped with modbus rtu and CMR provides a standard interface panel which shall communicate with all major BMS and PLC's to monitor and interrogate the CMR Fume Hood Controllers. The CMR Service Department can connect directly to the Interface panel via a VPN connection to provide fast after sales service.

Dedicated interface panels with Profinet, Profibus, Modbus IP, Bacnet IP etc. are manufactured by CMR.



CMR Compact Fast Actuator VMSM-05



DPC-320 Fume Hood Controller



Horizontal Operator Fume Hood Display Panel

DPC-320

CONTROL APPLICATIONS

FUME HOOD VARIABLE OR CONSTANT EXTRACT CONTROL WITH SUPPLY TRACKING OR ACTIVE ROOM PRESSURE CONTROL

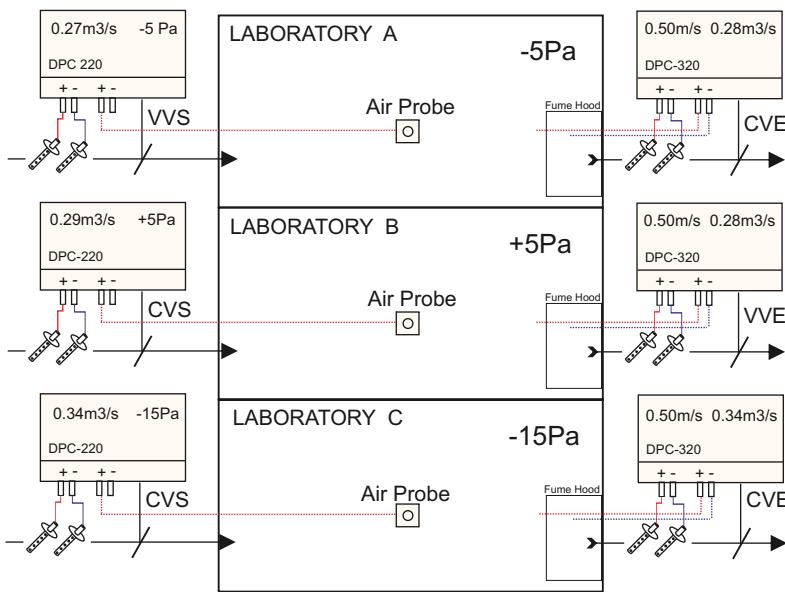

DPC320 and DPC220 Control

Laboratory A
The extract volume depends on the sash height of the Fume Hood. If the set point is 0.50m/s and the sash is open 500mm then 0.28m³/s is extracted. This is dictated by the Fume Hood manufacturer. The sub-net modbus communication is connected from the DPC320 to the supply DPC220 and the total extract volume is transmitted to the DPC220. The supply air is matched to the extract and the room pressure is also measured and a small off-set controls the -5Pa negative pressure in the Laboratory.

Laboratory B
This is the same as Laboratory A with the difference it is now controlled with an off-set to achieve +5Pa positive pressure.

Laboratory C
The laboratory is a clean room and it needs room pressure control of -15Pa at all times. The DPCs are now working independently. The Fume hood extract DPC320 works as usual controlling the face velocity at 0.50m/s but the supply air DPC220 measures the room pressure and controls the valve directly to maintain the room pressure at -15Pa.

The above schematic shows typical applications for the DPC controllers. The DPC is used for process and heavy duty industrial installations and they can be mounted on the valves in the field or in a central control panel, which makes calibration, maintenance and validation easier in future. Commissioning is very easy via the modbus network from remote.

The CMR PVC tubing can be run up to 200m in length to any of the above constant volume venturi valves and the chamber pressure air duct probes. The DPC is a standard controller which can be configured to provide constant supply, constant extract, variable volume supply or variable volume extract. It has the necessary interfaces to be set up as a tracking controller which means either supply or extract can be tracked with an adjustable off-set.

The CMR dampers and valves are fitted with CMR fast and heavy duty actuators and the mechanical connections and the gearboxes have been designed for continuous high torque and speed action. All DPCs can be connected to BMS, SCADA or PLC computer systems to read in the pressures, volumes and feedbacks and write set points, night set backs etc.

In case of BMS computer failure, the DPC reverts back to its default set points, a vital advantage in critical manufacturing processes. All DPCs have control freeze and timed release when chamber doors are opened and closed. The DPC is supplied with traceable calibration certificates to International Standards and site certification can be carried out by CMR. In fact CMR provides a complete commissioning and site calibration service.

TYPICAL STATIC PRESSURE AND CONSTANT FAN SPEED AND VOLUME DAMPER CONTROL APPLICATIONS

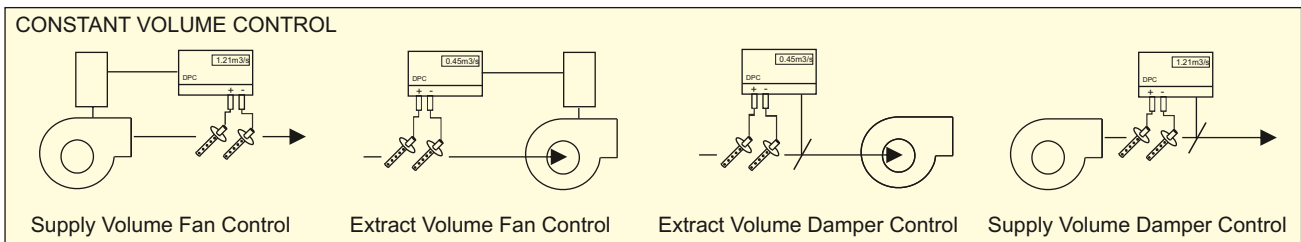
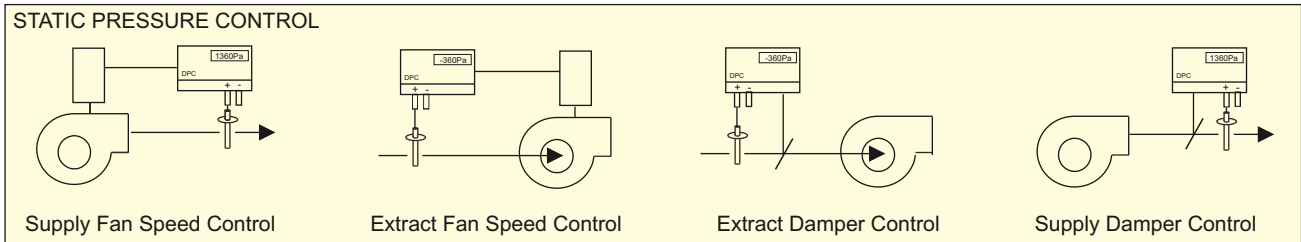

DPC-320

USER OPERATOR PANELS

CONTROL VALUE LCD

This LCD display indicates the actual Face Velocity across the sash of the fume cupboard.

CONTROL SET POINT

The control set point of the face velocity is set to 0.50 m/s. The set point is displayed in the lower left corner.

LOW FACE VELOCITY ALARM

The low alarm set point can be set to 0.40 m/s. If the velocity is lower than 0.40 m/s than it shall alarm after a time out. The internal timer is adjustable from 1 - 300s which means the alarm buzzer and light switches on after i.e. 20 seconds of the air flow being lower than 0.40m/s.

LOW EXTRACT VOLUME ALARM

The extract volume is monitored and shall control the extract damper to limit the volume in case the sash is totally open.

If the extract volume is too low and alarm can be raised which works identically to the low velocity alarm above.

MUTE ALARM

The BELL button is the mute button and by pressing it the buzzer shall switch off.

The alarm can be permanently muted via the parameter set up which is password protected.

CAL ON REMOTE DISPLAY PLATE

If the CAL is switched to ON the valve motor stops operating and the damper position is locked in the last position.

The tubes can now be removed from the velocity sensor and calibration work can be carried out safely.

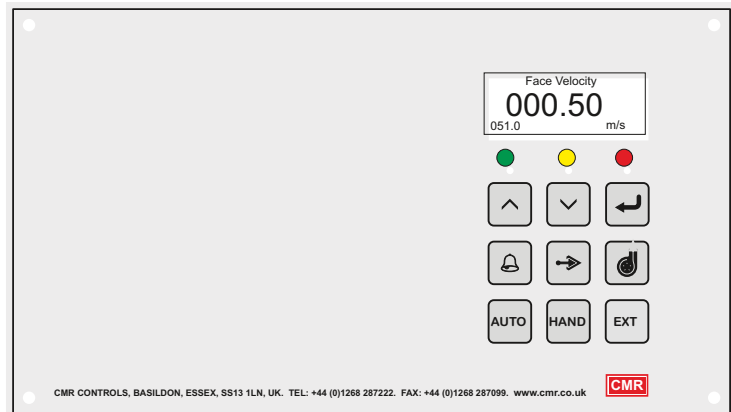

DPC-320 Controller Front Panel

AUTO OPERATION

The auto switch shall switch the fume cupboard controller in automatic control if it was switched to HAND. which means the valve motor works on face velocity control.

HAND OPERATION

If the switch is set to HAND position, the valve motor can be positioned with the UP and DOWN arrow keys which program the manual set point to any position from fully closed at 0% to fully open at 100%.

FAN BUTTON

This is an optional switch to power up a ventilator

PROGRAM BUTTON

This is used to enter the parameters into the controller and is password protected.

REMOTE FUME CUPBOARD DISPLAY AND ALARM CONTROLS

ALL HEALTHY

The green light is normally on if there are no alarms present. I.e. the face velocity is normal, the extract volume is normal and there is no sash high alarm then the green light is switched on.

SASH HIGH

If the sash high proximity switch is fitted then the yellow light would be used for the sash high alarm and the low velocity and low extract volume alarms would work in parallel.

MUTE ALARM

By pressing the BELL button the alarm can be muted.

TOGGLE SWITCH = VALVE SHUT

When this button is pressed it shall set the valve to shut position and by pressing the switch again it shall open the valve. The lower bottom left corner of the LCD shall show 'SHUT' if valve is closed.

NOTE:

This switch can also be used for custom applications

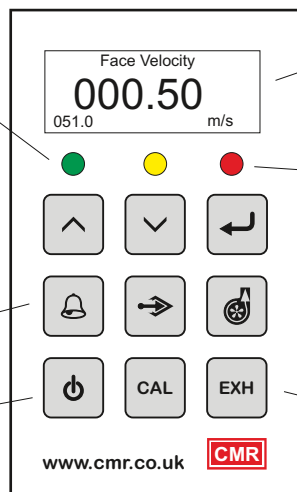

GRAPHIC LCD DISPLAY

The LCD display indicates the actual face velocity on the sash. The indicator is duplicated from the DPC controller Actual Velocity indicator and is scaled in m/s. The display is slower to indicate than the control action as dampening is programmed into the LCD.

ALARM

The red Alarm Light shall come on in case the face velocity or the extract volume is lower than the alarm set points. The buzzer shall come on as well if not permanently muted. When pressing the BELL button the buzzer can be muted and also reset if the alarm has been set to latching

EXH = EMERGENCY EXHAUST

When pressing the EXH panic button, the yellow light comes on and the airflow shall increase to a pre-adjusted set point up to 1.00m/s to provide an emergency extract in case of chemical spillages in the fume cupboard. The set point can be adjusted via the keyboard When pressing the EXH button again the yellow light will switch off and the air flow reverts back to its original set point .

DPC-320 Issue 2

PE	0-10V External set point	Gnd	D11 switch in external set point on T2	Gnd	D12 switch in hand operation	0-10V input from damper motor position	Gnd	0-10V scaled damper motor position out put	DI24V	3-10V Potentiometer for damper motor position	Gnd	0-10V input or output programmable external sensor	5-24V dc power supply for external sensors 150mA max	Gnd	0-10V actual sensor value output sensor 1	DI4 digital input door contact or force closed	+24Vdc	Remote Keyboard	GND	RS485 Tx+	RS485 Tx-	RS485 Rx+	RS485 Rx-	COM relay	NO relay	NC	DO out	GND	MOD_D1/RS232 TX	MOD_D0/RS232 RX	24Vac 800mA left	4-20mA Control out left	24Vac 800mA Power	0-10V Control out	24Vac 800mA right	L Power Input	N Power Input	PE Earth
1	2	3	4	5	6	7	8	9	10	11	12	13	14	15	16	17	18	19	20	21	22	23	24	25	26	27	28	29	30	31	32	33	34	35	36	38	40	

0-10V Set point for auto and hand control
 GND Ground (-) for all in- and outputs
 D11 to GND T3 switch in external set point on T2
 D12 to GND T3 switch in hand operation

0-10V scaled damper motor position

0-10V Sensor 2 measured value

0-10V Sensor 1 measured value

COM alarm relay
 NO alarm relay
 NC alarm relay

GND
 MODBUS rtu D1
 MODBUS rtu D0

BMS wiring from DPC to BMS (12 core shielded cable 0.5mm2)

T2 + Input 0-10V set point from BMS - T3 is GND

T4 to switch to GND T3 BMS to provide Volt Free Contact to switch in BMS set point on T2

T6 to switch to GND T3 BMS to provide Volt Free Contact to switch the DPC in Hand Mode.

When in hand mode - the set point from the BMS on T2 becomes the set point for the motor position

T9 + Output 0-10V scaled damper position feedback to BMS - T3 is GND

T13 + Output 0-10V sensor 2 scaled measured value - T3 is GND

T16 + Output 0-10V sensor 1 scaled measured value - T3 is GND

T24 common relay connection for digital input to BMS

T25 NO relay connection for GND of digital input channel of BMS

MODBUS rtu Wiring Belden 8102

T29 GND MODBUS rtu

T30 D1 MODBUS rtu

T31 D0 MODBUS rtu

DPC-320

0(2)..10V - 4..20mA ACTUATOR

DPC-320 Issue 2

1	2	3	4	5	6	7	8	9	10	11	12	13	14	15	16	17	18	19	20	21	22	23	24	25	26	27	28	29	30	31	32	33	34	35	36	38	40	
PE	0-10V External set point	Gnd	DI1 switch in external set point on T2	Gnd	DI2 switch in hand operation	0-10V input from damper motor position	Gnd	0-10V scaled damper motor position out put	DI24V	3-10V Potentiometer for damper motor position	Gnd	0-10V input or output programmable external sensor	5-24V dc power supply for external sensors 150mA max	Gnd	0-10V actual sensor value output sensor 1	DI4 digital input door contact or force closed	+24V/dc	GND	Remote Keyboard	RS485 Tx+	RS485 Tx-	RS485 Rx+	RS485 Rx-	COM relay	NO realy	NC/RTS	DI out/CTS	GND	MOD_D1/RS232 TX	MOD_D0/RS232 RX	24Vac 800mA left	4-20mA Control out	0 Vac	0-10V Control out	24Vac 800mA right	L Power Input	N Power Input	PE Earth

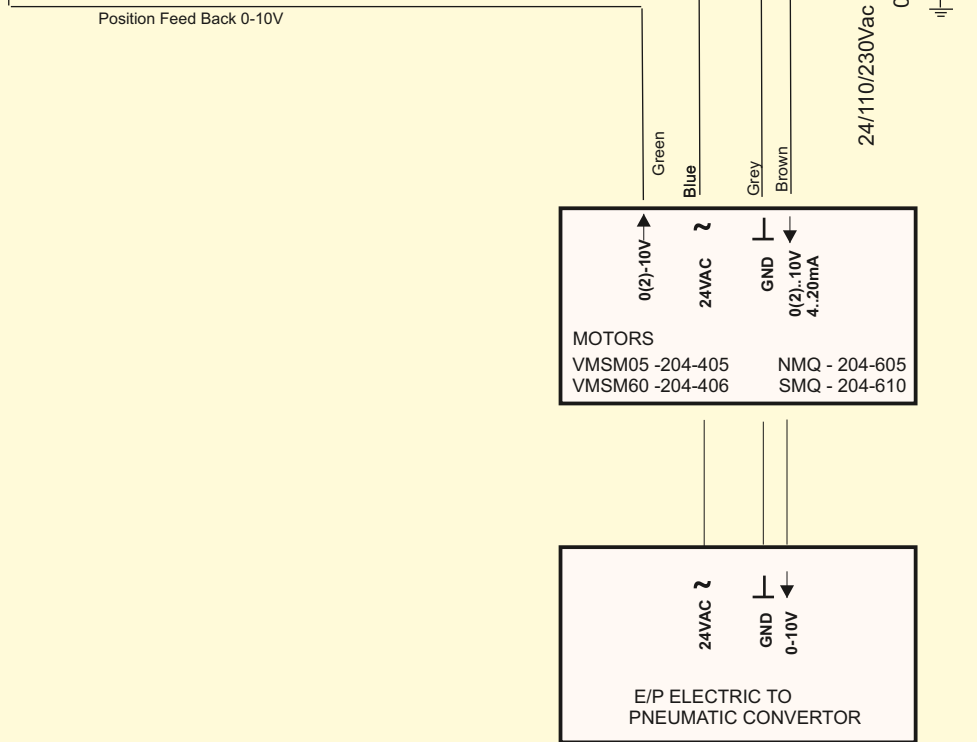

Above Drives have no limit switches must be ordered separately.

DPC-320 24VAC TRI-STATE ACTUATORS

DPC-320 Issue 2

1	2	3	4	5	6	7	8	9	10	11	12	13	14	15	16	17	18	19	20	21	22	23	24	25	26	27	28	29	30	31	32	33	34	35	36	38	40
PE	0-10V External set point	Gnd	DI1 switch in external set point on T2	Gnd	DI2 switch in hand operation	0-10V input from damper motor position	Gnd	0-10V scaled damper motor position out put	DI24V	3-10V Potentiometer for damper motor position	Gnd	0-10V input or output programmable external sensor	5-24V dc power supply for external sensors 150mA max	Gnd	0-10V actual sensor value output sensor 1	DI4 digital input door contact or force closed	+24V/dc	GND	RS485 Tx+	RS485 Tx-	RS485 Rx+	RS485 Rx-	COM relay	NO	realy	GND	MOD_D1/RS232 TX	MOD_D0/RS232 RX	24Vac 800mA left	4-20mA Control out	0 Vac	0-10V Control out	24Vac 800mA right	L Power Input	N Power Input	PE Earth	

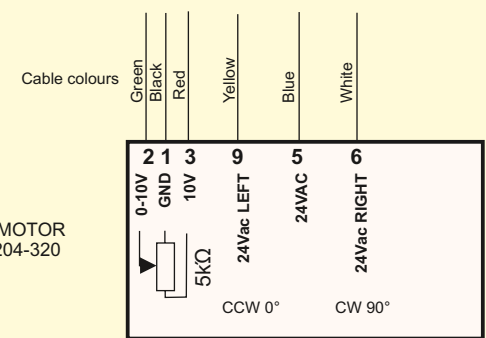
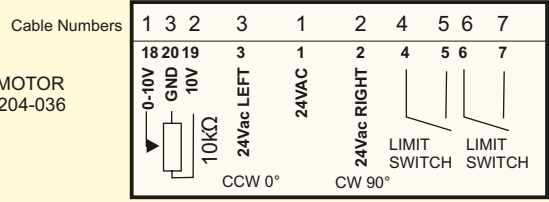
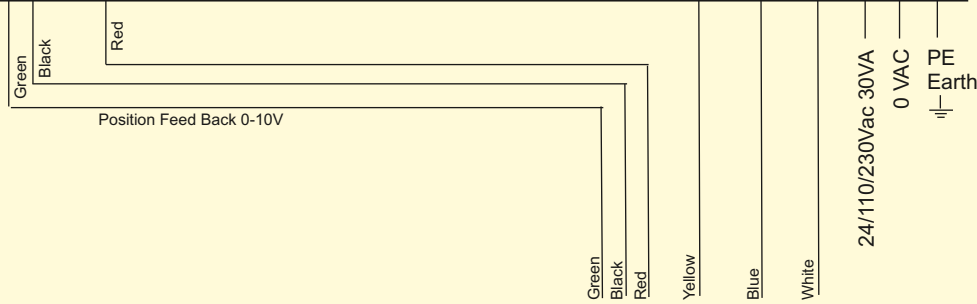

All limit switches must be adjusted to switch off motor on both sides.

DPC-320

ORDER DESCRIPTION

GENERAL

CMR manufactures the DPC-320 wall mount fume hood face velocity controller to suit many applications. Because of the variety of functions and power supplies it has been necessary to design an easy to use selection table for anybody to make up a DPC-320 controller specification to satisfy a requirement. You will find all specifications available with the associated ordering Code on the DPC-320 Controller Selection Table (Page 7) . In order to select the correct part we have made up a sample selection below:

DPC-320 PART NUMBER

The DPC-320 Part Number starts with the selection of the controller type '78'.

DPC-220 Board Issue No.

The DPC-320 will have an update on the electronic board from time to time and to identify the issue No i.e. for software and hardware, this number might change. For Issue 2 the Code is '2'.
The Part Number extends to '782'

TUBE NIPPLES

The DPC-320 is normally supplied with 6 mm barbed tube nipples..
We have selected Nipple Size 6mm which has the Code 'A'.
The Part Number extends to '78 2 A'.

SENSOR 2 RANGE

The sensor 2 is the volume limiting sensor, which measures the extract volume. The sensor is always standard 250 Pa.
In the example we have chosen Range '250'
The Part Number extends to '78 2 A 0250

UNITS OF MEASUREMENT FOR SENSOR 2

The measurement units are expressed in Pascals .
The code is 'P'.
We have chosen Mode 'P'.
The Part Number extends to '78 2 A 0250 P

SENSOR 1 RANGE

The sensor 1 is normally the controlling sensor , which measures the face velocity. The sensor is always standard 2.00 m/s .
In the example we have chosen Range '0002'
The Part Number extends to '78 2 A 0250 P 0002

UNITS OF MEASUREMENT FOR SENSOR 1

The measurement units are expressed in meter per second m/s.
The code is 'V'. We have chosen Mode 'V'.
The Part Number extends to '78 2 A 0250 P 0002 V

CABLE GLANDS

The DPC-320 is normally supplied with Glands so that the motor cable, remote display plate and communication can easily be installed by an electrician to be terminated on terminals.
We have selected Glands which has the Code '0'.
The Part Number extends to '78 2 A 0250 P 0002 V 0

POWER SUPPLY

The DPC-320 can be ordered in
24VAC with Code '3'
110VAC with Code '4'
230VAC no power cable fitted with Code '5'
230V UK complete with cable and UK plug with Code '6'
230V EU complete with cable and European plug with Code '7'

All cables are 3m long .
We have chosen 230V with cable and UK plug which has Code '6'.
The Part Number extends to '78 2 A 0250 P 0002 V 0 6.

FINAL PART NUMBER

The Part Number to order is '78 2 A 0250 P 0002 V 0 6.

Now try and select your own DPC-320 using the DPC-320 Order Selection Table.

DPC-320 FUME HOOD SPECIFICATION

Measurement Range	Sensor 1 = 0...2 m/s face velocity sensor and Sensor 2 = 0.. 250 Pa for extract volume sensor
Optional Range	Any Range from 1.00m/s to 2.00m/s or up to 10,000 Pa
Overload Capacity	To 340mBar
Media	Non Corrosive Gases such as Air,N ₂ ,O ₂ ,CO ₂ ,N ₂ O, inert Gases
Sensor 1/ 2 Type	1. Air Velocity Mass flow / 2. Pressure
AC Power Supplies	24 VAC 50/60Hz Fuse 1.0 A Wickmann
	110VAC 50/60Hz Fuse 315 mA Wickmann
	230VAC 50/60Hz Fuse 315 mA Wickmann
AC Control Output	24 VAC (internal power from isolation transformer) max 850mA (Fused 1A Wickmann)
	Triac output
DC Control Output	0(2)..10Vdc and 4..20mA
Sensor Output Voltage RL = 5kOhm min	0-10V (0...100% of Range)
	.
Hysteresis/Repeatability	0.3% Typical of Full Scale
Linearity (Accuracy)	Sensor 1 = 1% FS 2.00 m/s - Sensor 2 0.25% of Full Scale > 100 Pa - 0.25Pa of Full Scale < 100 Pa
Zero Drift	0.02%K (+10°C to +50°C) - 0.0% with Auto Zero
Hand - Auto Key	On keyboard or Digital input on T4 external set point switch T6 change over from auto to hand
External Set Point	0...10V on T2
Position Input	0...10V on T7
Alarm Threshold	On keyboard Programmable
Control Function	Off-Set - Sensitivity - Proportional Band - Timing / Integral - Ramp Speed - output Freeze
Alarm Relays	1A 24VDC / AC Low/High Alarm single pole - Buzzer and repeater single pole on-off.
Operating Temperature	+10°C to +40°C (Storage -40°C to +70°C)
Mounting Position	Vertical or Horizontal
Weight	1.5 kg
Electrical Connections	1 x 20mm 4 x 16mm Gland Internal screw Connections.
Air Tube Connections	2 x Positive and Negative Nipple 6.5mm O/D x 15mm long standard for CMR PVC tube
Communication	2 x Modbus rtu Plus Remote Keyboard Modbus rtu
Enclosure	ABS Grey with clear front Lid - Protection Class IP65.
Conformity	EN61326-1 EMC EN61010-1 SAFETY
Calibration Certificate	Calibration Certificate traceable to International Standards is supplied for the DPC320 pressure sensor

